

INLET PROTECTION

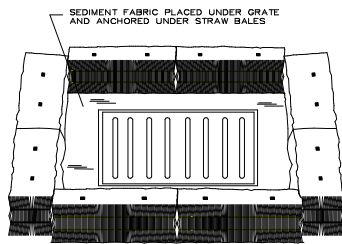

STRAW BALE BARRIER

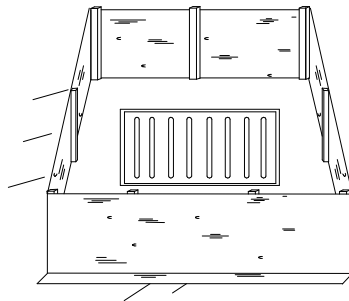

SILT FENCE

SEE INDIVIDUAL BMP INFORMATION SHEETS FOR INSTRUCTIONS FOR CONSTRUCTION OF STRAW BALE BARRIER AND SILT FENCE..

OBJECTIVES

- 9 Housekeeping Practices
- 9 Contain Waste
- 9 Minimize Disturbed Areas
- 9 Stabilize Disturbed Areas
- 9 Protect Slopes/Channels
- : Control Site Perimeter
- : Control Internal Erosion

DESCRIPTION:

Sediment barrier erected around storm drain inlet.

APPLICATION:

Construct at storm drainage inlets located downgradient of areas to be disturbed by construction (for inlets in paved areas see other information sheets for inlet protection).

INSTALLATION/APPLICATION CRITERIA:

- < Provide upgradient sediment controls, such as silt fence during construction of inlet.
- < When construction of inlet is complete, erect straw bale barrier or silt fence surrounding perimeter of inlet. Follow instructions and guidelines on individual BMP information sheets for straw bale barrier and silt fence construction.

LIMITATIONS:

- < Recommended maximum contributing drainage area of one acre.
- < Limited to inlets located in open unpaved areas.
- < Requires shallow slopes adjacent to inlet.

MAINTENANCE:

- < Inspect inlet protection following storm event and at a minimum of once monthly.
- < Remove accumulated sediment when it reaches 4-inches in depth.
- < Repair or realign barrier/fence as needed.
- < Look for bypassing or undercutting and recompact soil around barrier/fence as required.



TARGETED POLLUTANTS

- ▣ Sediment
- 9 Nutrients
- 9 Toxic Materials
- 9 Oil & Grease
- ▣ Floatable Materials

| |
|-------------------------|
| ▣ High Impact |
| : Medium Impact |
| 9 Low or Unknown Impact |

- 9 Other Waste

IMPLEMENTATION REQUIREMENTS

- : Capital Costs
- 9 O&M Costs
- : Maintenance

| | | |
|--------|----------|-------|
| ▣ High | : Medium | 9 Low |
|--------|----------|-------|

- 9 Training